



AMBIPOWER® MDc-180 HEAT PUMP

ONE OF AUSTRALIA'S POWERFUL AND EFFICIENT SMALL INTEGRATED HEAT PUMPS*

RHEEM AMBIPOWER® MDc-180 HEAT PUMP

The AmbiPower® MDc-180 Heat Pump is for replacement of small to medium Electric Water Heaters. It is an energy efficient alternative for areas where a traditional solar water heater may not be suitable. It uses the heat from the surrounding air to heat your water and provides a reliable, efficient and sustainable way to reduce your water heating energy consumption.

A Heat Pump can work day and night as it extracts heat from the surrounding air and doesn't rely on direct sunlight to operate.



AMBIPOWER®
180L HEAT PUMP



FEATURES

- Advanced wrap around microchannel heating technology for uniform and faster water heating
- Suitable for cold climates with an operating range from -7°C to +43°C²
- Suitable for harsh water conditions³
- Can save up to 70% on your water heating energy consumption compared to an electric water heater in Zone 3⁴
- 2.4 kW back-up element
- User-friendly touch screen LED display
- Eligible for STCs (may be eligible for additional incentives in some states)
- 7 year cylinder warranty⁵
- Suitable for 1 to 3 people

WHY CHOOSE A RHEEM HEAT PUMP?

AmbiPower® MDc-180 Heat Pump has been designed and tested to withstand the harsh Australian conditions:

Enamel lined water tank reduces the risk of corrosion.

Microchannel technology provides a larger contact area for more efficient water heating.

Side fan design provides maximum airflow and protects from the rain.

Durable outer shell in painted sheet metal design to reduce corrosion and withstand harsh weather conditions.

LED touchscreen controller provides optimum visibility, product performance information and user-friendly operation.

COP¹ – The Coefficient of Performance for a Heat Pump is the ratio of how much useful heat it produces for water heating to the power input into the water heater. The higher the COP number, the more efficient the Heat Pump is.

Ambient Air Temperature and Humidity – The performance of a Heat Pump changes with ambient air temperature, humidity and incoming water temperature. The warmer the air temperature, the higher the Relative Humidity and the cooler the water temperature, the higher is the heating rate of the Heat Pump. Performance specifications stated in relation to the Heat Pump are measured at predefined conditions during its testing.

Average Heating Capacity (kW) – This is how much heating power is put into the water during the heating cycle. It is expressed as an average due to the changes in heating power from the refrigeration cycle as the water is being heated and its temperature increases during the heating cycle.

Hot Water Recovery Rate @ 45°C rise (L/hr) – Is the number of litres of water that can be heated through a 45°C temperature rise in one hour, e.g. when the air temperature is 19°C, the Heat Pump can heat 60 litres of water from 15°C to 60°C in one hour.

*Based on a comparison of ≤ 200L air source electric integrated hot water Heat Pumps registered with the Australian Government's Clean Energy Regulator www.cleanenergyregulator.gov.au/DocumentAssets/Pages/Air-source-heat-pump-models.aspx published on Version 49 - Published 16 August 2023 and based on factors including heating output, coefficient of performance and water recovery rate using R134a refrigerant.





AMBIPOWER® MDC-180 HEAT PUMP

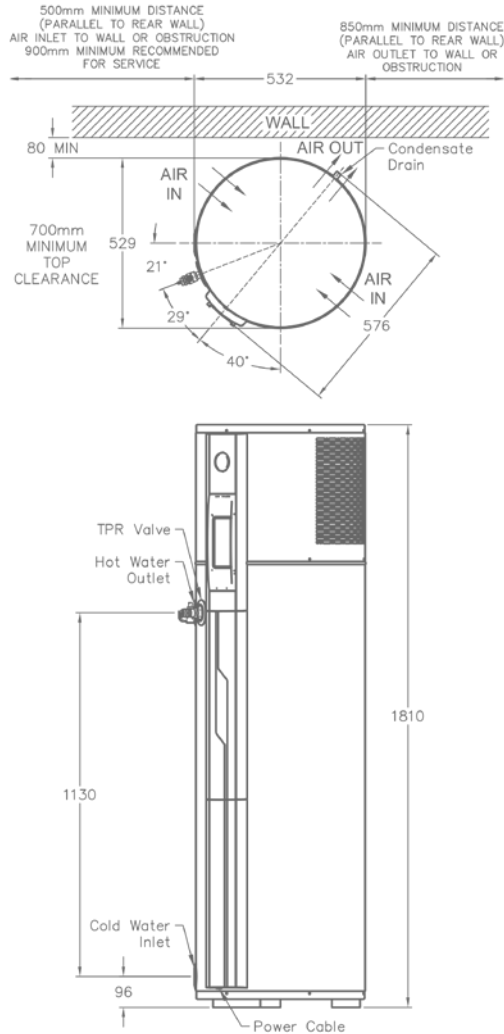

AMBIPOWER® MDC-180

MODEL	UNIT	551180
Storage capacity	Litres	178
Boost capacity	Litres	168
Rated Heat Pump power input	Watts	683
Element rating	kW	2.4
Recommended electrical circuit	Amps	15
Coefficient of Performance (@19°C) ¹		4.5
Noise Level @ 1 metre ⁶	dB(A)	48
People per household		1 to 3

Dimensions & specifications

Tank height	mm	1810
Tank width	mm	532
Tank depth	mm	576
Heater weight - cartoned	kg	116
Heater weight - full	kg	284
Refrigerant		R134a

Water connections & settings

Inlet & Outlet		Rp 3/4
Temperature Press Relief (TPR) Valve setting	kPa	1000
Expansion Control Valve (ECV) setting	kPa	850

Maximum mains supply pressure

With expansion control valve	kPa	680
Without expansion control valve	kPa	800

HEAT PUMP PERFORMANCE SPECIFICATIONS

Ambient air temperature	Recovery rate @ 45°C rise (L/hr)	Average heating capacity (kW)	Coefficient of Performance (COP) ¹
19°C	60	3.1	4.5

BACK-UP ELEMENT RECOVERY RATE @ 240 V TEMPERATURE RISE OF

Rating (kW)	30°C (litres/hour)	40°C (litres/hour)	50°C (litres/hour)
2.4	69	52	41

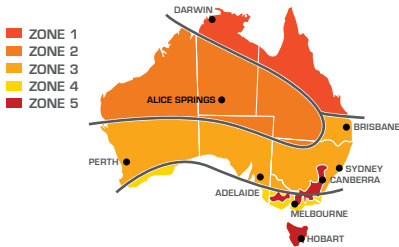

STCs

Small-scale Technology Certificates (STCs) provide a financial incentive to encourage the installation of Solar and Heat Pump water heaters provided under a Federal Government legislated scheme.

This map shows the climate Zones within Australia which will define the number of STCs allocated to an approved Heat Pump water heater. Your installation may be eligible.

For more information on STCs visit www.rheem.com.au/rheem/help/offers-and-incentives/stcs

- The COP of 4.5 is the average value in the AS/NZS5125 performance test at 19°C ambient temperature over the entire heat-up process. Note that the actual COP of the product at any given time will be impacted by a number of factors, including the ambient and cold-water inlet temperatures at the place of installation and time of day/season of operation.
- The specified -7°C to 43°C temperature range is the operational range of the Heat Pump. The electric element activates when the ambient air temperature is outside this range and heating of the water is required.
- Warranty limits regarding water chemistry. Harsh water regions – the Rheem warranty may not apply if the water heater is connected to a water supply which has a Total Dissolved Solids content >2500mg/L; is scaling with a Saturation Index >+0.8, or; is corrosive with a Saturation Index <-1.0.
- Energy savings of up to 70% are based on Australian Government approved TRNSYS simulation modelling using a medium load in Zone 3 and apply when replacing an electric water heater of similar size with a Rheem 551180 Heat Pump water heater. Any savings will vary depending upon your location, type of water heater being replaced, hot water consumption and fuel tariff. Before installation - seek advice as to suitability to household usage and tariffs. The impact on an electricity account will depend on the tariff arrangement of the water heater being replaced and where you live. The water heater is recommended for connection to an uninterrupted 24 hour continuous tariff power supply. Depending upon the size of the household and its hot water requirements and if the Electricity Retailer permits, an extended off-peak (overnight and day) or Extended time controlled power supply connection of a minimum 16 hours per day may also be suitable. Before purchase consult your energy provider for more information on cost comparisons.
- Warranty Periods: 7 years supply on cylinder, 3 years labour on cylinder, 3 years supply on sealed system including labour, 1 year supply and labour on all other parts. Applies to a single-family domestic dwelling only. Conditions apply. See the Rheem warranty set out in the Owner's Guide and Installation Instructions or view at www.rheem.com.au/warranty
- Noise Level – A noise level of 48 dB(A) was measured at 1 m from the water heater during a Noise Test conducted to Standard GB/T 23137-2008 in a hemi-anechoic chamber within a laboratory. The noise level when installed may be higher due to sound reflections from adjacent walls and structures.



A Greater Degree of Good™ represents our global commitment to sustainability.



Rheem Australia Pty Ltd.
1 Alan Street, Rydalmere,
NSW 2116 Australia
PO Box 7508, Silverwater
NSW 2128 Australia
www.rheem.com.au



®Registered Trademark of Rheem Australia Pty Ltd. ™ Trademark of SAI Global. Materials and specifications are subject to change without notice.

COMES ON STEADY, HOT AND STRONG

INSTALL A

